



The Business Benefits of Data Modeling

Donna Burbank
Global Data Strategy, Ltd.
December 3, 2024





Achieving Data Value with erwin by Quest

**Presenter Danny Sandwell, Solutions Marketing
Quest Software**

Today's erwin portfolio

Data Marketplace and Data Products

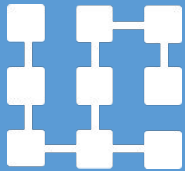

Data Modeler

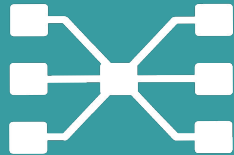

Data Catalog



Data Quality

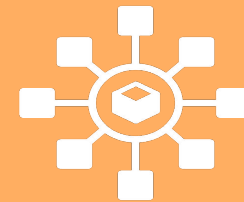

Data Literacy

Data Governance

Data Intelligence Strategies, Challenges & Impacts

- **YOY, 36% more orgs cite they now have a clearly articulated data intelligence strategy (61% of orgs overall) and have benefits to show :**
 - improved employee productivity through self-service [42%]
 - revenue growth through decision-making [40%]
 - cost-savings [34%]
 - risk mitigation [33%]
 - enhanced data visibility [33%]
- **Data modeling is in focus with 1 in 4 orgs planning to integrate within data intelligence initiatives in next 24 months.**

2024 State Of Data Intelligence Survey/Report – ESG/erwin by Quest

Data products and data modeling

- **Top benefits of delivering data products** include
 - improved decision-making given higher quality of data provided 51%
 - improved collaboration and communication from unified data across org 49%
 - data analysis is better given business context around data 47%
 - greater trust in data given comprehensive support surrounding data delivery 43%
- **84% of organizations now deliver data products with 86% of those who do modeling the data products delivered**
 - Of those modeling data products, **72% cite reduced time in data product development and deployment** as a significant or game-changing benefit
- **Other top significant to game-changing benefits through data modeling** include:
 - collaborative blueprint for business requirements 73%
 - providing a data governance foundation 72%
 - encourages collaboration between IT and business 71%

Maximizing the Business Impact of Data

e.on ensures energy continuity for
51 million customers
with erwin by Quest

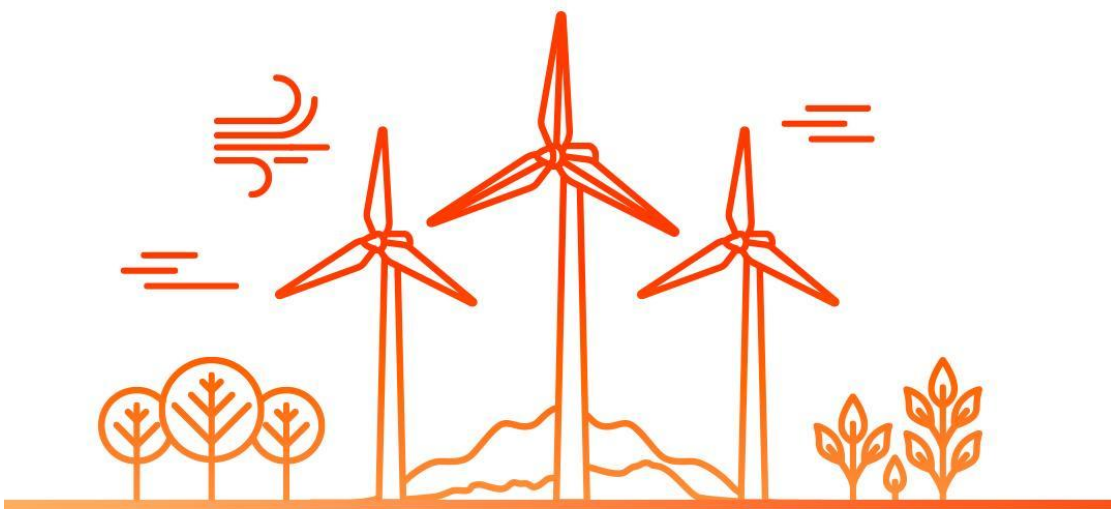

International energy supplier

- ✓ E.ON is using erwin for **Metadata Management, Data Governance and Data Modeling**
- ✓ 24 business units, 600 erwin users in 2023

30% savings in external data management costs

50% reduction in data discovery time

2m Euros in business impact saved in first 24 months

7 steps to maximize data value

with erwin® by Quest® data modeling and intelligence

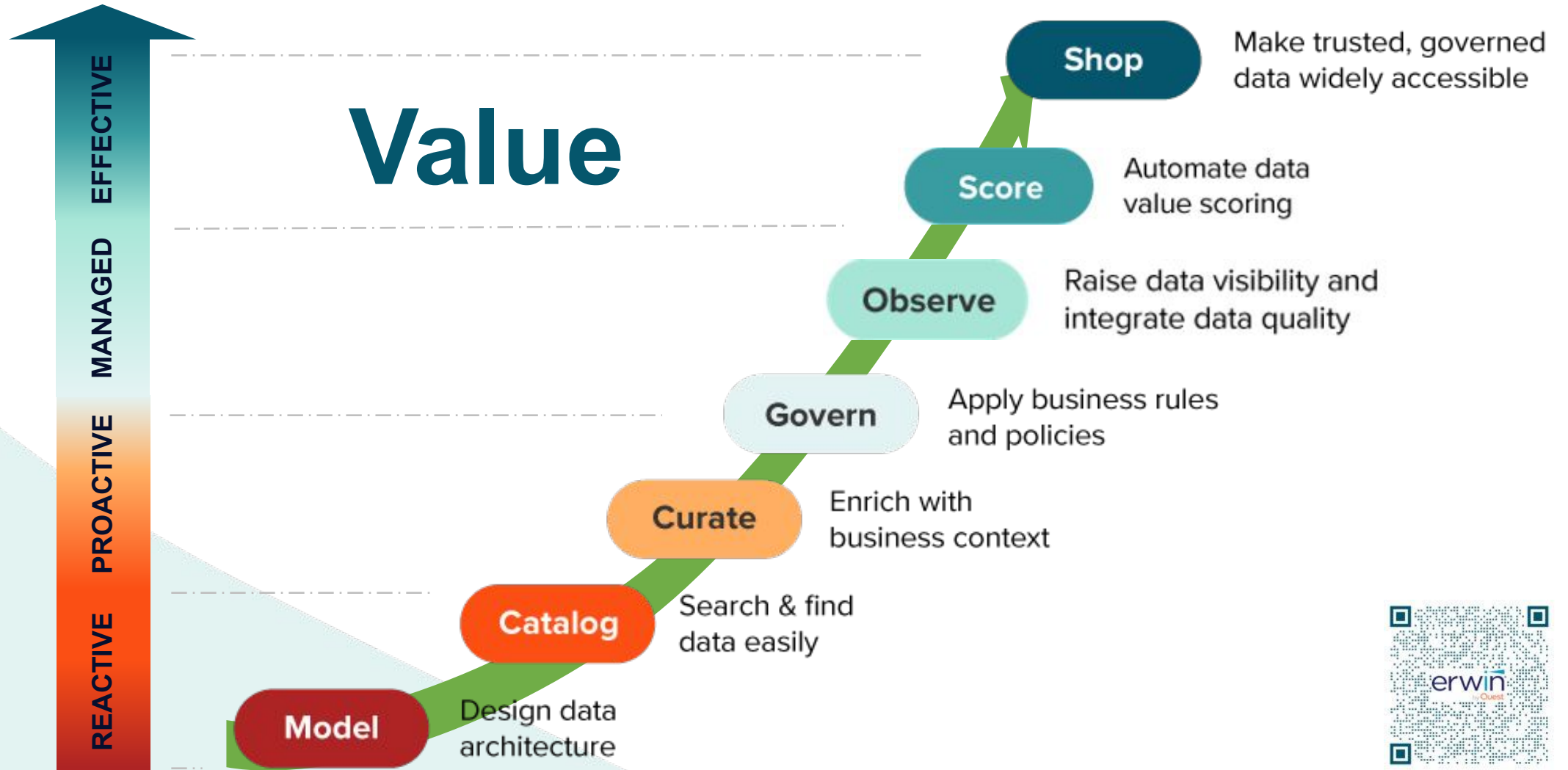

Donna Burbank



Donna is a recognized industry expert in data management with over 25 years of experience in data governance, metadata management, and enterprise architecture. Her background is multi-faceted across consulting, brand management, brand strategy, marketing, and business leadership.

She is currently the Managing Director at Global Data Strategy, Ltd., an international data management firm that specializes in the alignment of business drivers with data-centric technology.

In past roles, she has served in key brand strategy and product management roles at CA Technologies, where she worked on several of the leading data management products in the market.

As an active contributor to the data management community, she is a long time DAMA International member, Past President and Advisor to the DAMA Rocky Mountain chapter, and was awarded the Excellence in Data Management award from DAMA International.

She has worked with dozens of Fortune 500 companies worldwide in the Americas, Europe, Asia, and Africa and speaks regularly at industry conferences. She has co-authored several books and is a regular contributor to industry publications. She can be reached at donna.burbank@globaldatastrategy.com Donna is based in Boulder, Colorado, US.



DATAVERSITY Data Architecture Strategies

This Year's Lineup

- **January** Emerging Trends in Data Architecture – What's the Next Big Thing?
- **February** Building a Data Strategy - Practical Steps for Aligning with Business Goals
- **March** Master Data Management - Aligning Data, Process, and Governance
- **April** How do Data Governance & Data Architecture Support Each Other?
- **May** The Role of the Chief Data Officer (CDO) in Business Transformation
- **June** What Does It Mean to be a Data-Driven Organization?
- **July** Data Architect vs. Data Engineer vs. Data Scientist – Making Sense of Roles in Today's Data-Centric Organization
- **August** Data Quality Best Practices (with Nigel Turner)
- **September** Best Practices in Metadata Management
- **October** Enterprise Architecture vs. Data Architecture
- **December** The Business Benefits of Data Modeling



What We'll Cover Today

- **Data models are key to gaining a clear view of the data that drives the business** – from customers to products to invoices and more.
- They offer a clear, **visual way for both business and technical stakeholders to communicate** around the crucial business rules and definitions that drive both operational usage of data as well as analytics and reporting.
- This webinar will provide **practical, concrete steps in creating valuable data models** that can show immediate value to the organization, while at the same time building towards a full-enterprise view.



A little data modeling up-front ... prevents headaches down the road

- It's often tempting to skip data modeling documentation because it's "faster"
- But...long-term, it's ultimately longer as errors and inconsistencies need to be fixed as a result.

"If you don't have time to do it right, do you have time to do it again?"



Levels of Data Models

Audience

Purpose

Business Stakeholders
Data Architects

Organization & Scoping of main
business domain areas

Enterprise
Subject Areas

Business Stakeholders
Data Architects

Communication & Definition of
Business Concepts & Rules

Conceptual
Business Concepts

Data Architects
Business Analysts

Clarification & Detail
of Business Rules &
Data Structures

Logical
Data Entities

DBAs
Developers

Technical
Implementation on
a Physical Database

Physical
Physical Tables

Data Modeling Usage Trends

What types of models and diagrams do you use in your Data/Enterprise Architecture?

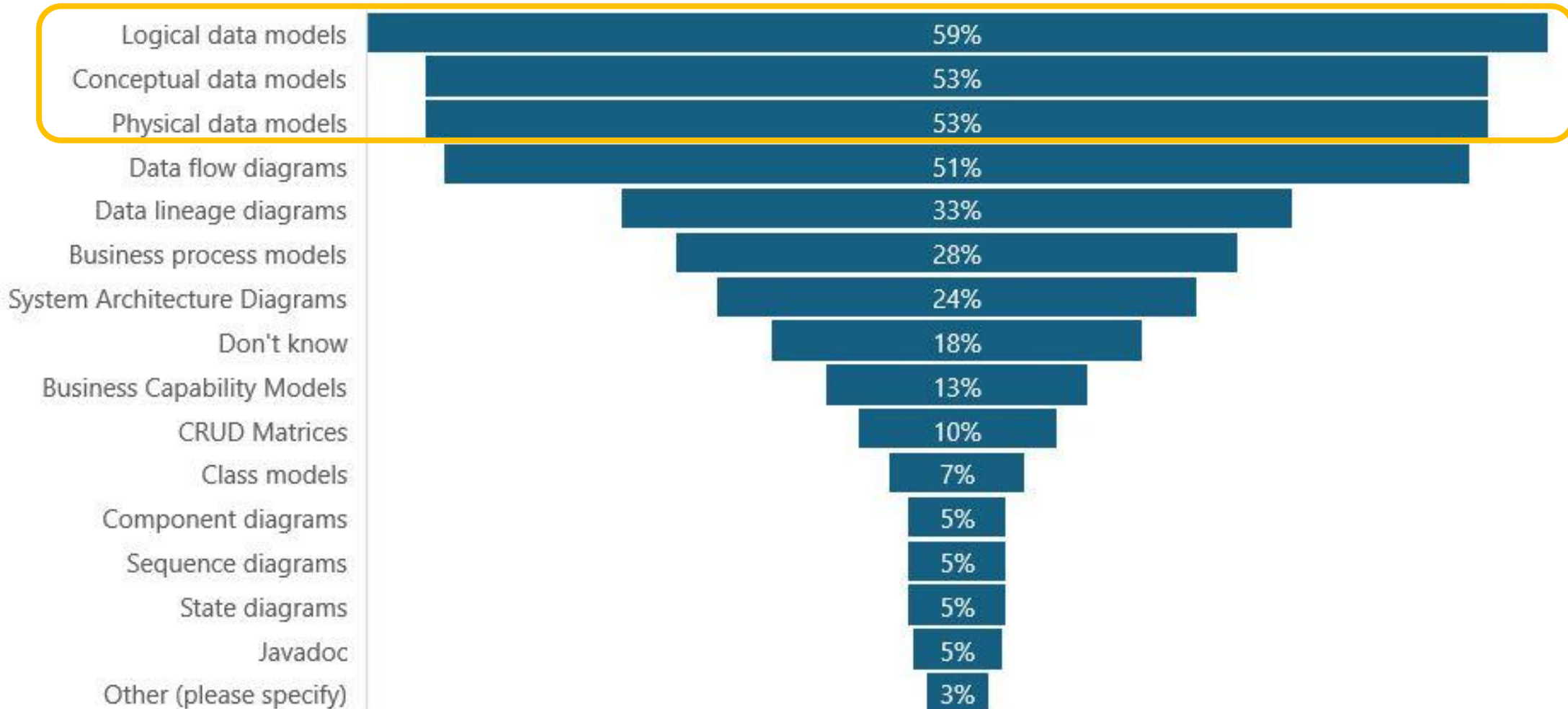

Use the Language of Your Audience

Gaining Buy-In

- When communicating with business stakeholders, it's important to display data models in a way that's intuitive to them
 - PowerPoint-style Conceptual Data Models
 - Use Business Terminology
 - Avoid Excess Detail

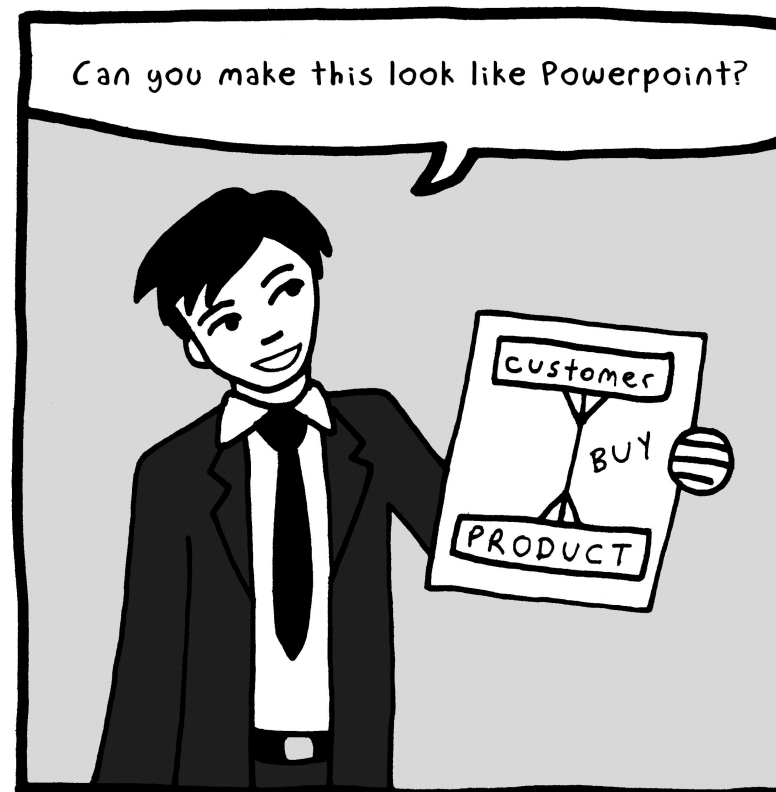

From [Data Modeling for the Business](#) by Hoberman, Burbank, Bradley, Technics Publications, 2009

Business Data Model (Conceptual)

- Communication & definition of core data concepts & their definitions

- A business data model provides core **definitions** of key data objects.

- It also shows key **relationships** between data objects.

- Even a simple diagram as the one on the right can tell a powerful **“story”**

.... And uncover key **business issues and opportunities.**

- How do we define a “customer” vs. a “client”

- Is our employee relationship different for each?

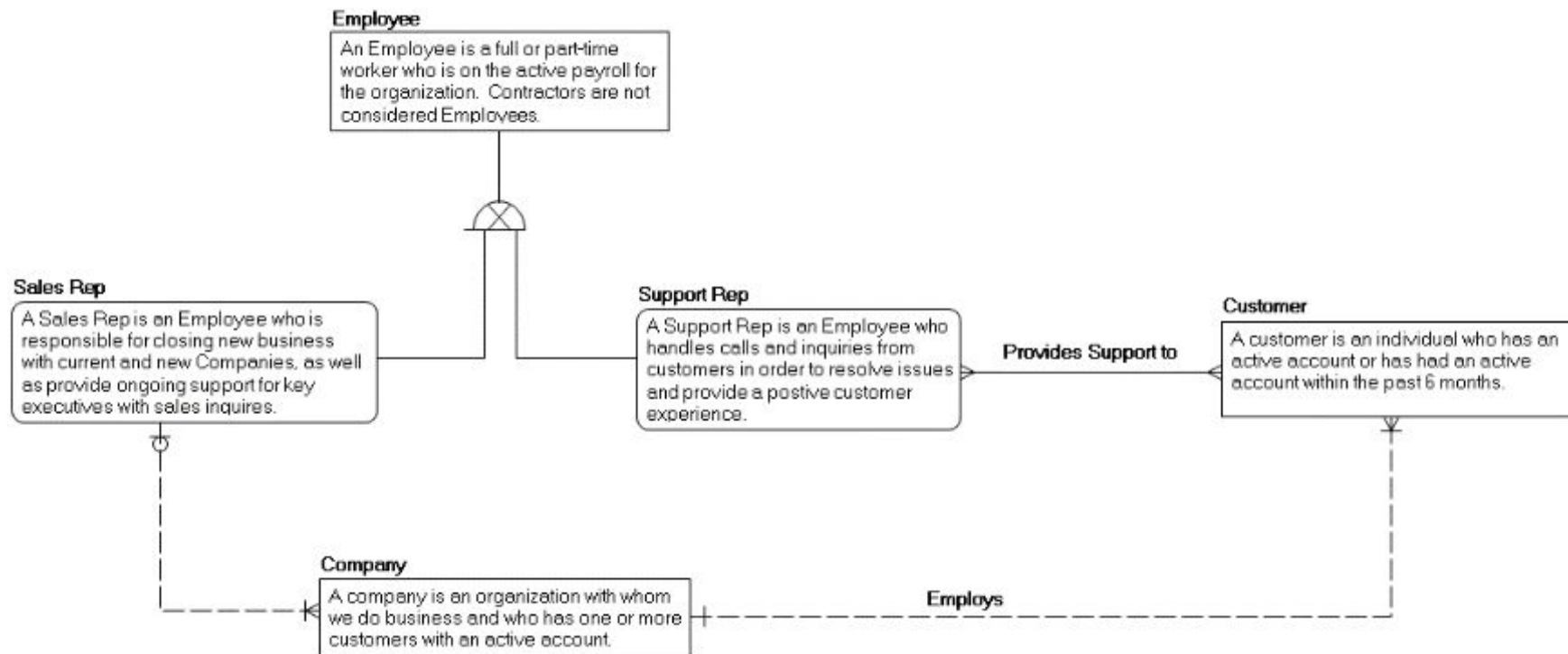

Business Data Model (Conceptual)

- Including a graphical version of a data model is often a helpful way to tell the “story”

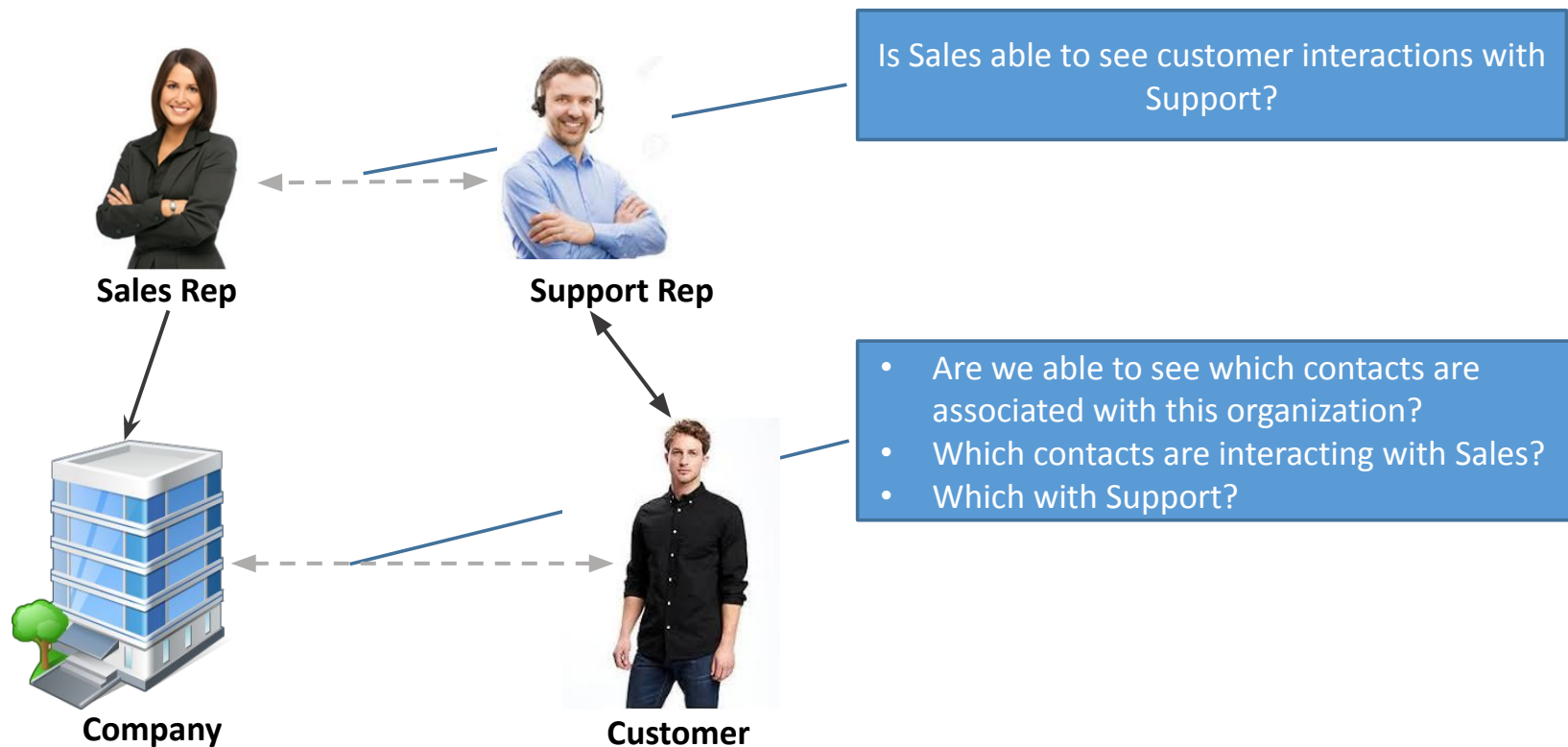

A Picture is worth a thousand words.

Tell a Story

What impact does the data model have on the business?

- Humans have evolved over time as storytellers
 - We can't even sleep without dreaming in stories.
- No one cares about your data model...
 - ... but they do care about the RESULTS of your data model
 - ... **relate the model to a real world impact or scenario..i.e. "story"**

Humans are Storytellers.



From Data Modeling for the Business by Hoberman, Burbank, Bradley, Technics Publications, 2009

Real-World Quotations from Business Users

This is really elegant. You just summed up our organization in a single page.

- Early Childhood Educator

I'd never seen data from the Customers' perspective before. This will totally help me in my application development. Thank you!

- VP of Software Development

We have two more departments asking if you can build one of those data model diagrams for them.

- Clinical Health Organization

I love this data model. The last architect told me I couldn't possibly understand this stuff, but when presented this way, it makes total sense—it's so logical!

- Evaluation & Analytics Lead

This explains why our campaigns aren't working.

- Chief Marketing Officer

Hand me the pen...

How did you learn so much about our company in one week? Are you sure you never worked here before?

- Utility Company

The Value of Whiteboarding

It's often helpful to "whiteboard" data models with sticky notes

- Short whiteboard sessions with key stakeholders can flesh out key metadata definitions & scope in a short period of time.
- And it can be fun and interactive.

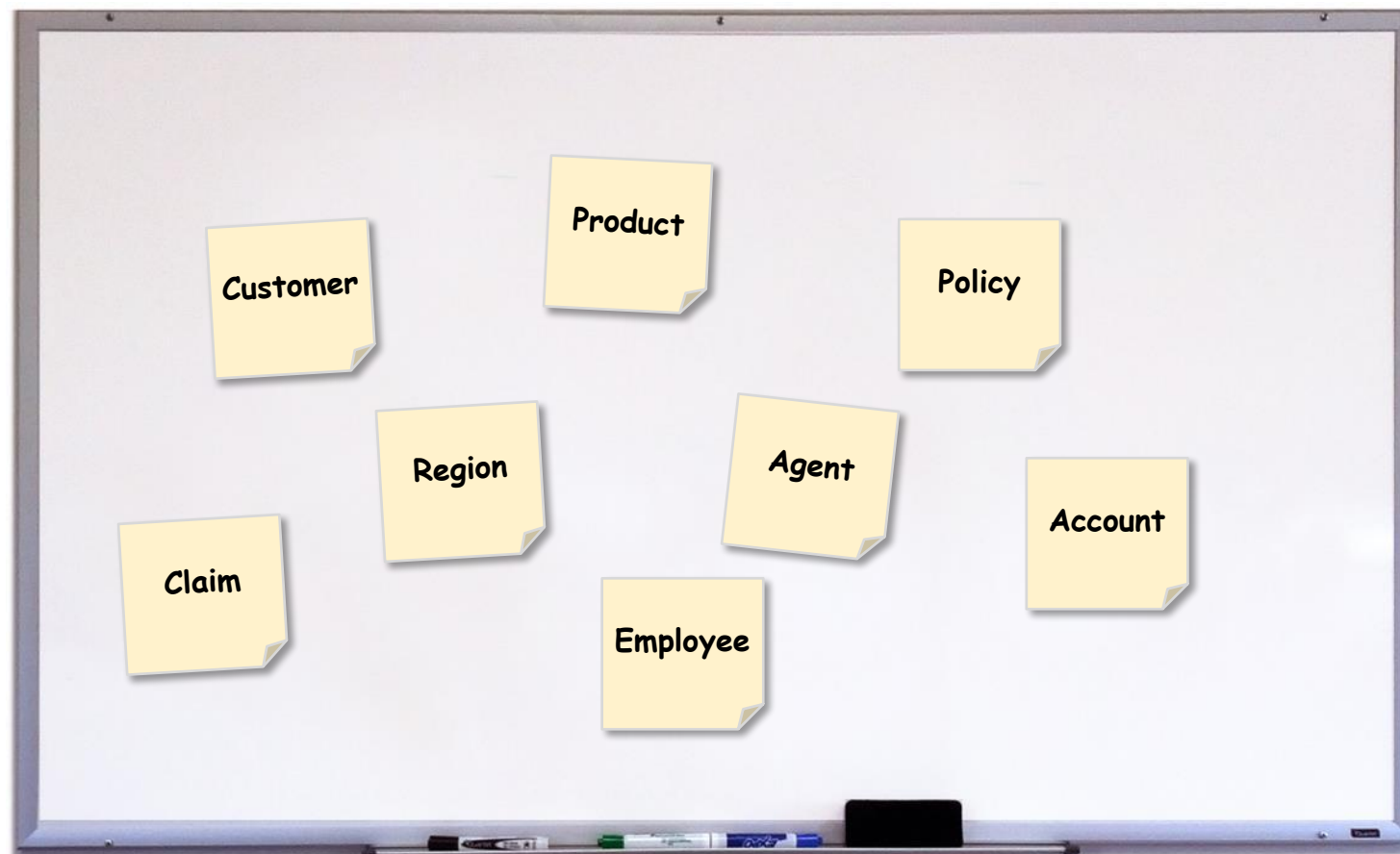

Data Models Describe the Organization

- Relationships define the **data-centric Business Rules of an organization**
- You should be able to “**read**” a **data model like a sentence**.
- The **Entities / Concepts** are the “**nouns**” – the **boxes** on a data model
- It’s often helpful to start by taking some text describing the organization (or transcripts from stakeholder interviews) and draw boxes around the nouns to find the core entities
 - An employee can work for more than one department.
 - A customer can have more than one account.
 - A department can contain more than one employee.

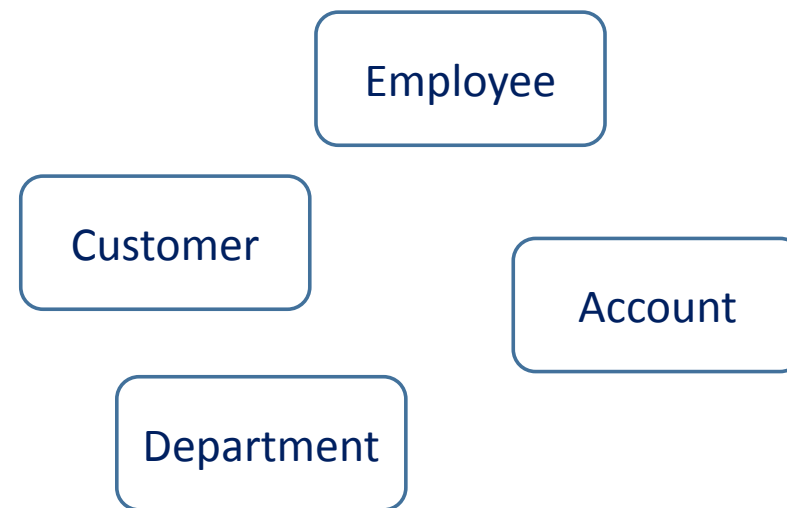

Data Models Describe the Organization

- Relationships are the “**verbs**” in a sentence.
- It’s easy to spot the relationships by underlining the verbs in a sentence:
 - A department can contain more than one employee.
 - A customer purchases a product
- With this combination of boxes for nouns and lines for verbs, you have a data model!



Logical Data Model

- A logical data model
 - Defines detailed business rules
 - Includes attributes, data types, nullability, etc.
 - Defines data structures, but not physical tables (e.g. hierarchies)
 - And uncovers key business issues and opportunities.
 - Can a customer have more than one address?
 - Is Fax number still a required field?
 - What is a fax number???....

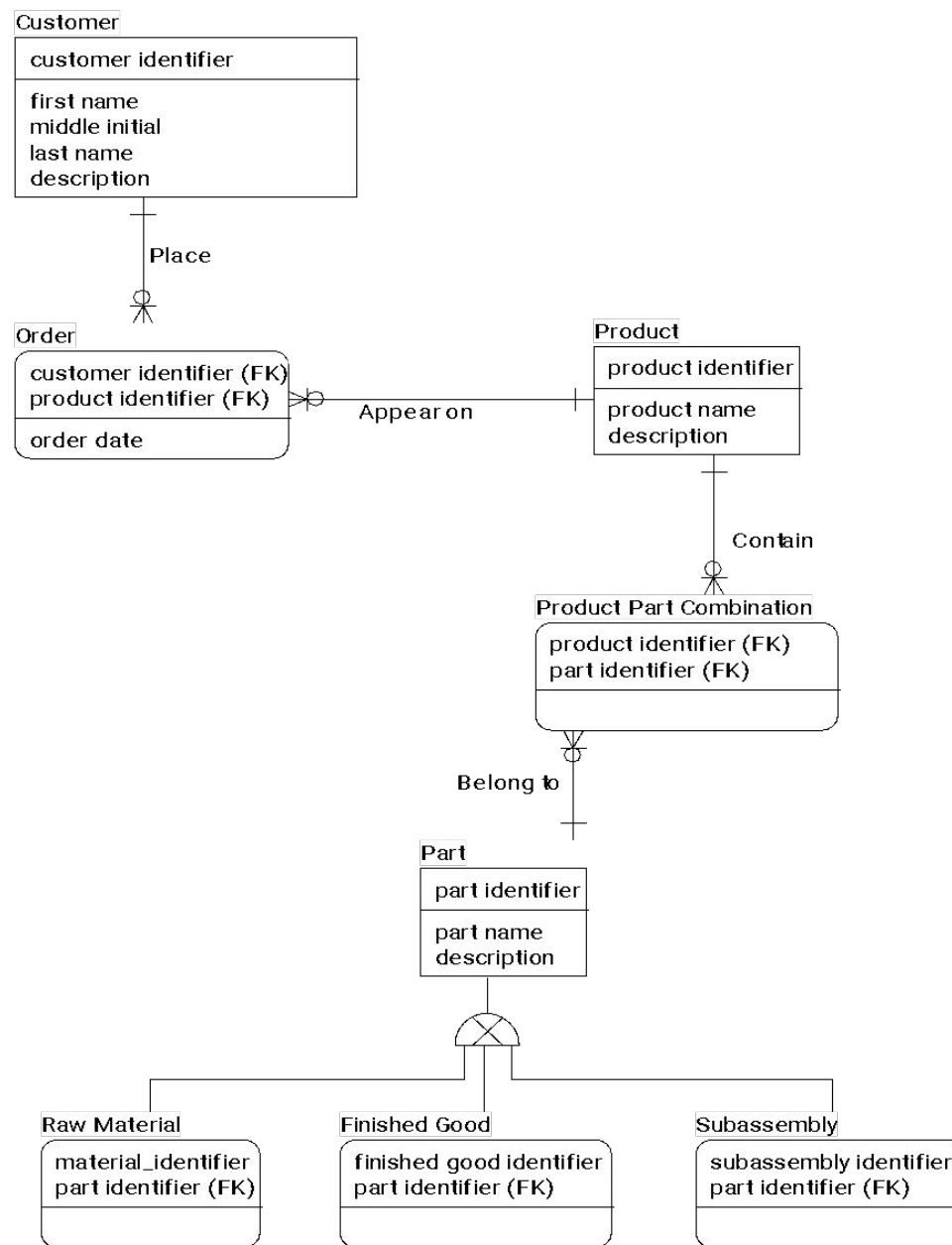

- The Environment Agency worked with Global Data Strategy to develop **Data Models & Data Standards** in order to support Open Data publication of key environmental measures.
 - Land boundaries
 - Air & Water Quality
 - Fish & Wildlife populations
- **Common Data Models & Standards helped create a common lingua franca across the organization:**
 - Saving time & money
 - Supporting Regulation
 - Enhancing public reputation
 - Improving data quality & consistency
 - Increasing collaboration between teams



“Establishing a standard is a really important step in bringing our information together so we can be better joined up, better integrated and **work together more efficiently**. In short, if you’ve got even the slightest interest in how we plan and deliver outcomes on the ground, you should be taking an interest in this!”
- National River Basin Operations Manager, Environment Agency

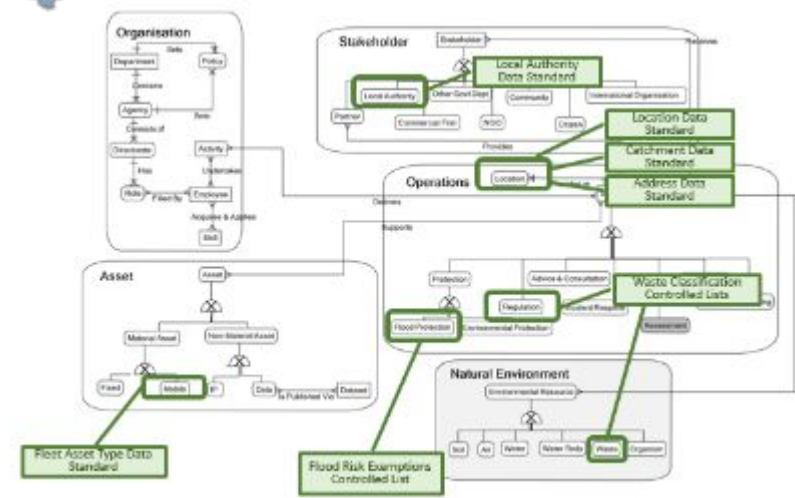

Business Modeling at Kiewit**

It's all about Architecture

- Understanding the data that supports the business – architecture & construction
- Supporting data governance efforts – aligning business & IT
- Integrating data silos across the organization – single view of data assets



** See March 2021 DATAVERSITY webinar [here](#)

Architecture vs. Construction

- It's a common analogy to use building architecture as an analogy to data architecture.
- When constructing a building, there is a clear distinction between designing a house and building a house.



Design

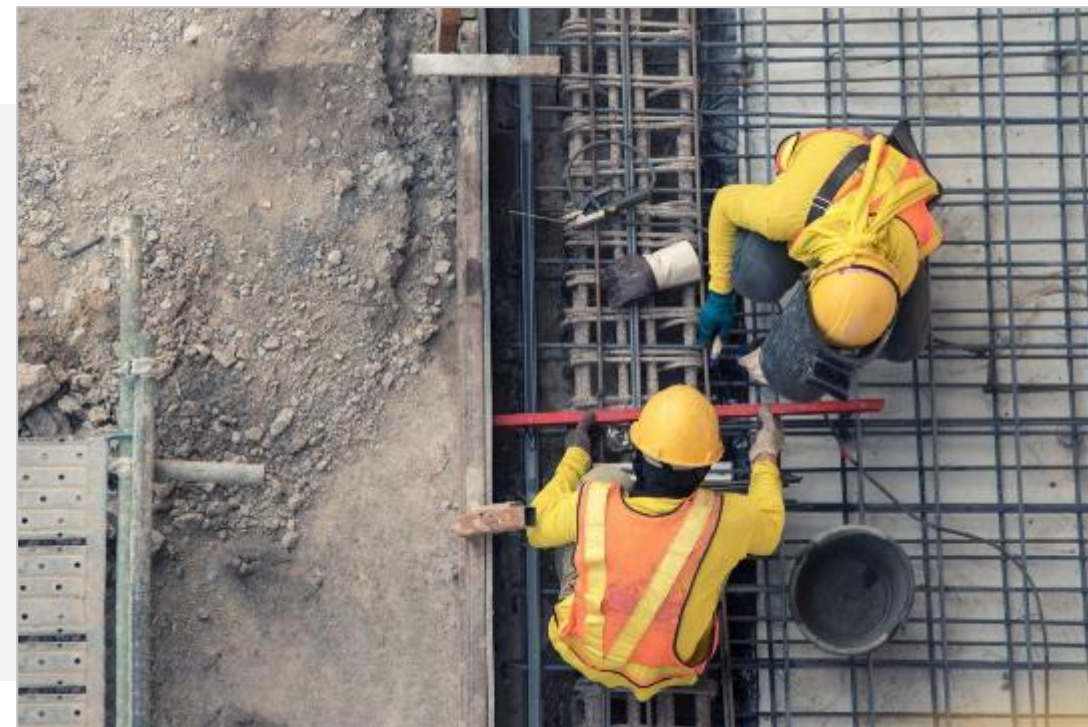

Build

Architecture vs. Construction

- When constructing a database, there is a clear distinction between designing and building.

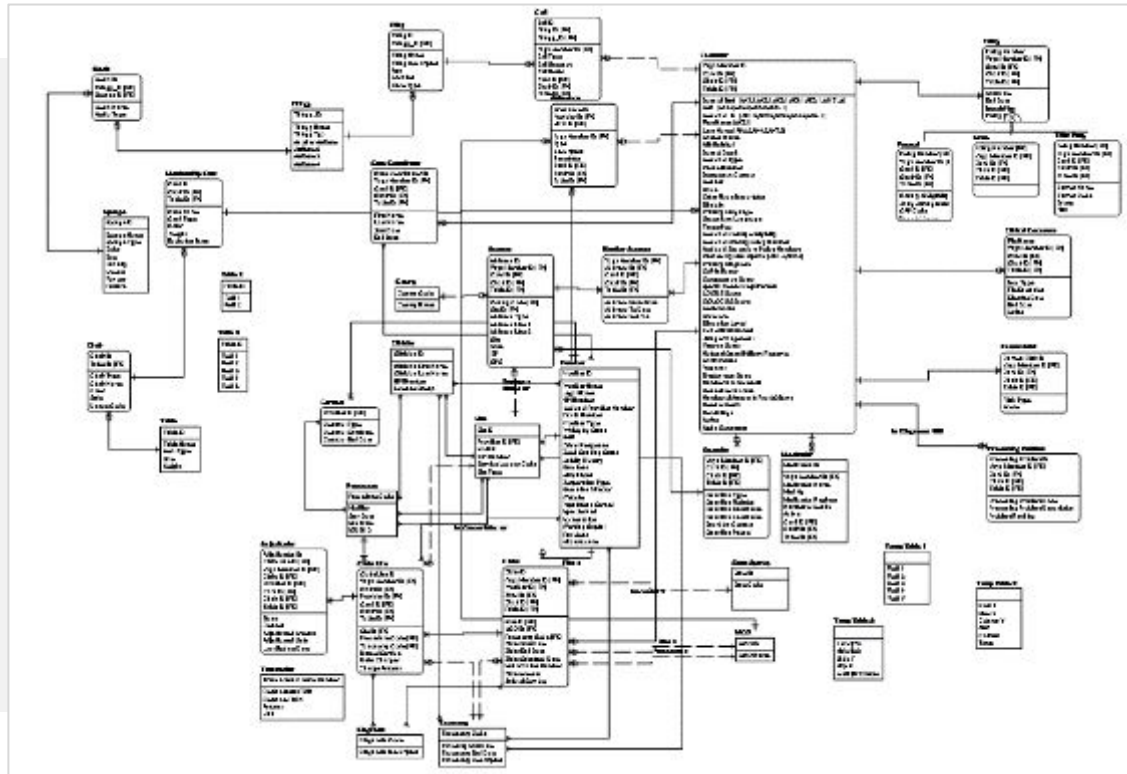

Design

3

Build

```

product_id    INTEGER NOT NULL,
product_name  VARCHAR(50) NULL,
product_price NUMBER NULL);

ALTER TABLE PRODUCT
ADD ( PRIMARY KEY (product_id) );

CREATE TABLE DEPARTMENT (
department_id  INTEGER NOT NULL,
department_name VARCHAR(50) NULL);

ALTER TABLE DEPARTMENT
ADD ( PRIMARY KEY (department_id) );

CREATE TABLE EMPLOYEE (employee_id
INTEGER NOT NULL,
department_id  INTEGER NOT NULL,
employee_fname VARCHAR(50) NULL,
employee_lname VARCHAR(50) NULL,
employee_ssn   CHAR(9) NULL);
ALTER TABLE EMPLOYEE
ADD ( PRIMARY KEY (employee_id) );

CREATE TABLE CUSTOMER (
customer_id    INTEGER NOT NULL,
customer_name  VARCHAR(50) NULL,
customer_address VARCHAR(150) NULL,
customer_city  VARCHAR(50) NULL,
customer_state CHAR(2) NULL,
customer_zip   CHAR(9) NULL);

ALTER TABLE CUSTOMER
ADD ( PRIMARY KEY (customer_id) );

CREATE TABLE ZORDER (
zorder_id    INTEGER NOT NULL,
employee_id  INTEGER NOT NULL,
customer_id  INTEGER NOT NULL,
zorder_date  DATE NULL);

ALTER TABLE ZORDER
ADD ( PRIMARY KEY (zorder_id) );
    
```

Physical Data Model

- A physical data model
 - Defines data structures to store data on a physical platform (e.g. RDMBS, Document data store, etc.)
 - Optimizes for performance, query, etc.
- ... And ensures that data is stored in a fit for purpose manner. e.g. How can I:
 - Store data to reduce redundancy and increase data quality?
 - Optimize data storage to “slice and dice” for self-service analytics?
 - Optimize data storage for speed of query?

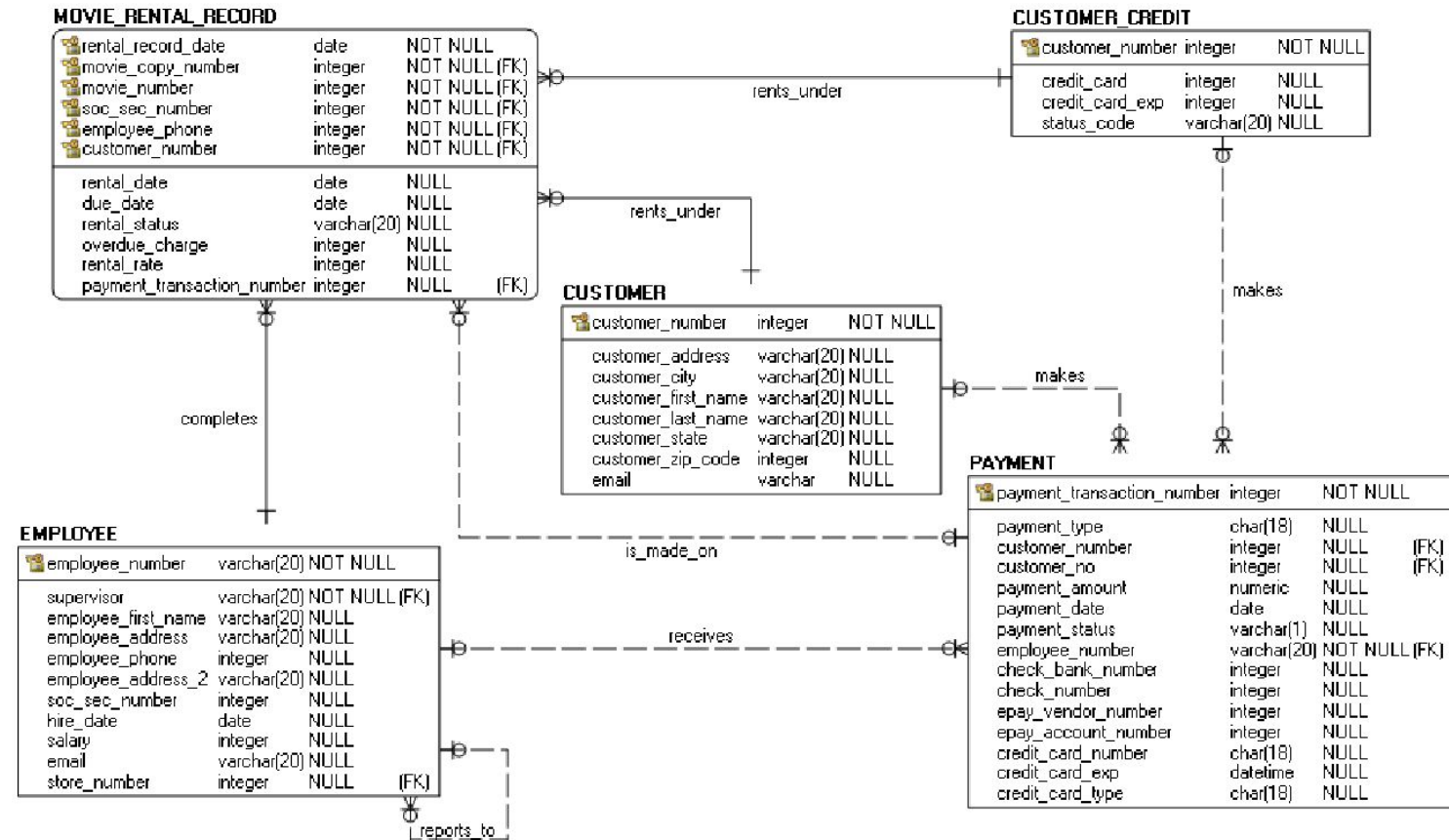

Avoid “Death by Data Modeling”

- “We’re just going to sit in this room for a few days until we scope out the entire enterprise data model plastered across these three walls.
- Just about 1000 entities or so...
- First off, what is the data type for account code? ...”

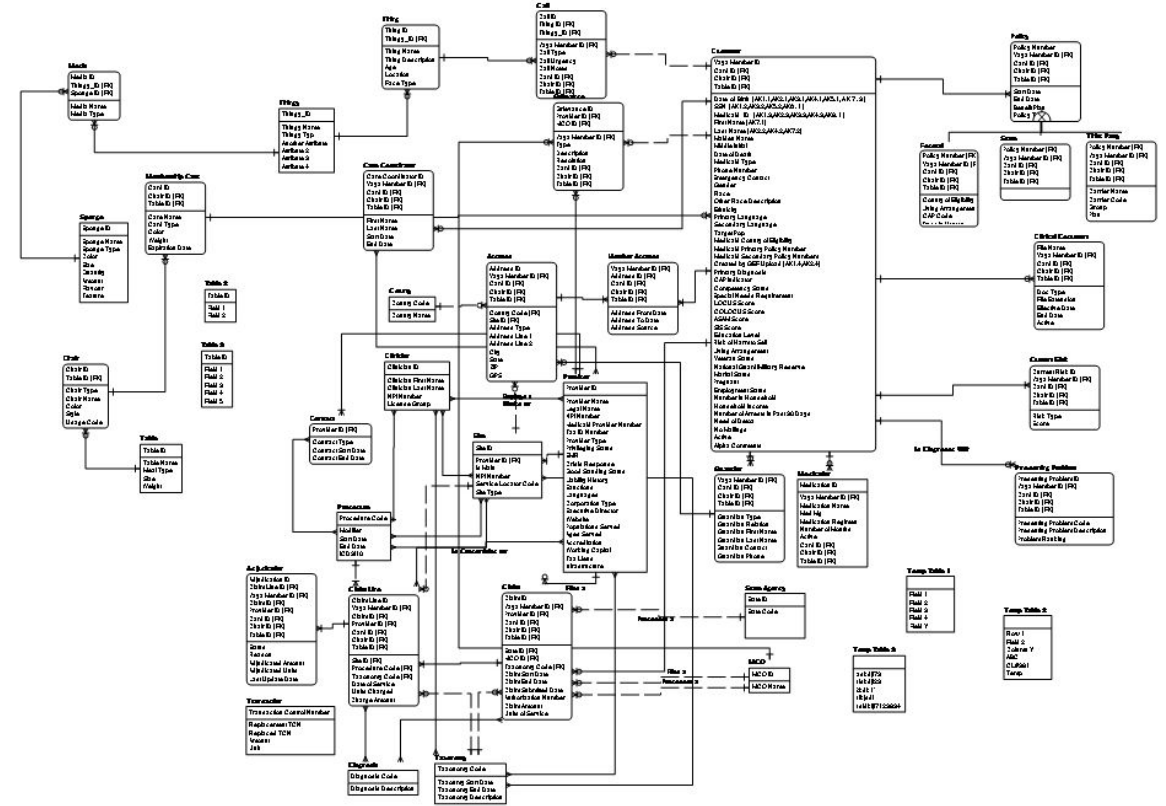

Break the Large Modeling Efforts into Manageable Chunks

Instead of creating large models all at once

Break them into smaller “chunks” / sprints

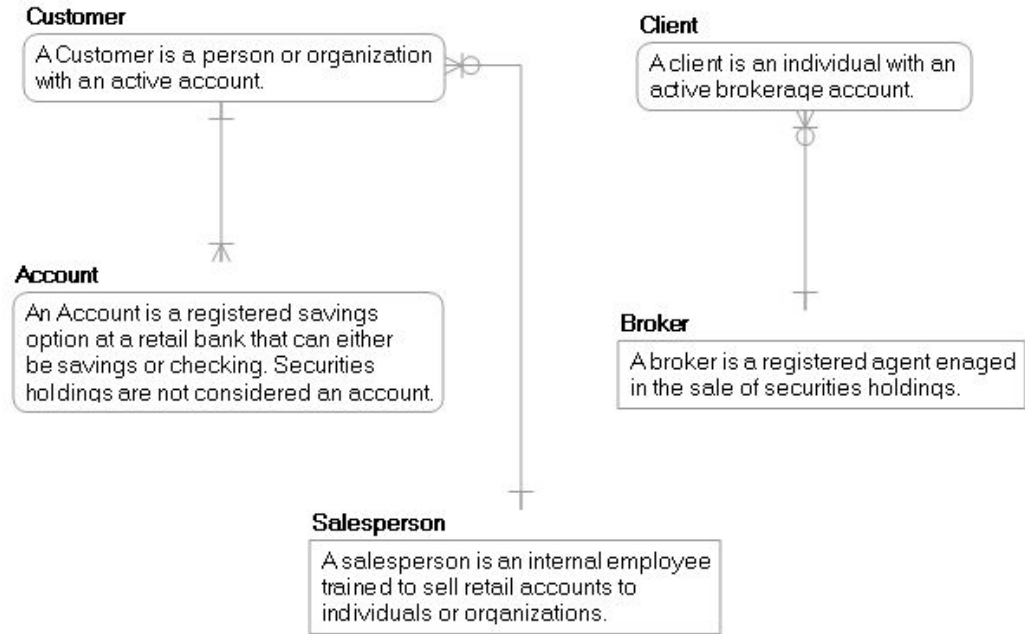
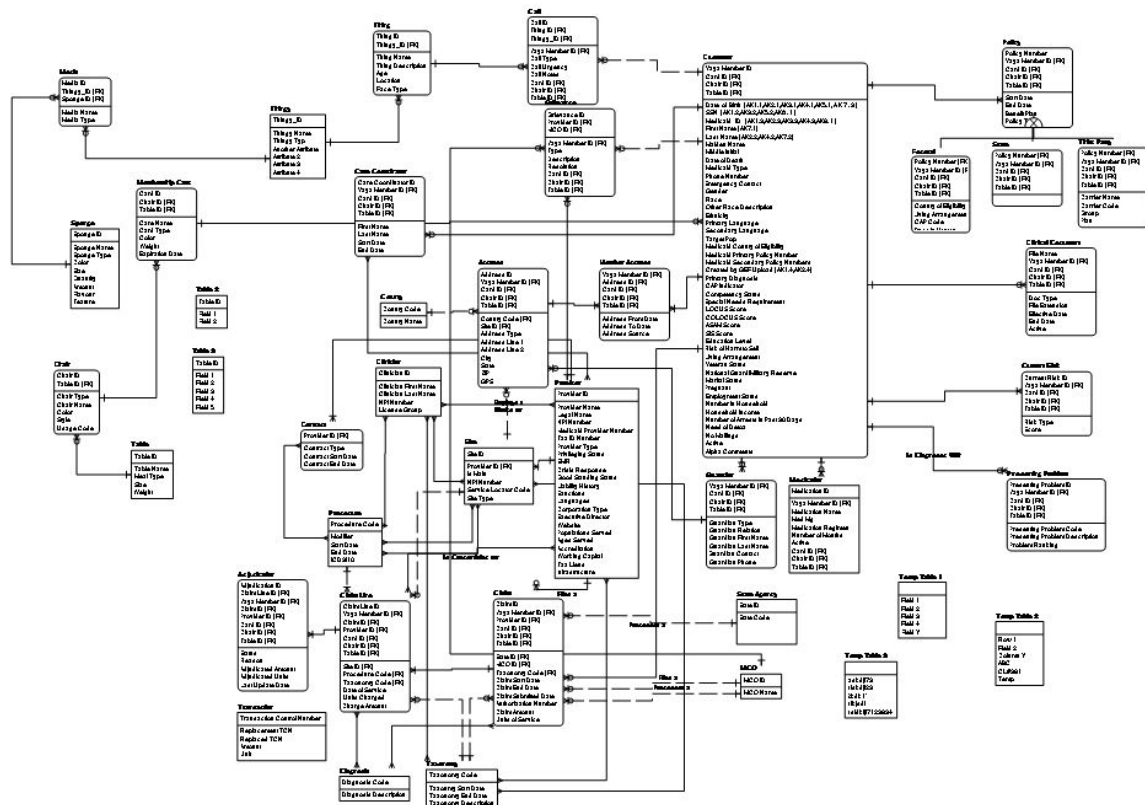

Data Modeling Creates an “Active Inventory” of Data Assets

- **Know what data you have:** Create a visual inventory of database systems
- **Know what your data means:** Communicate key business requirements between business and IT stakeholders
- **Support data consistency:** Build consistent database structures & support data governance initiatives

Data Models

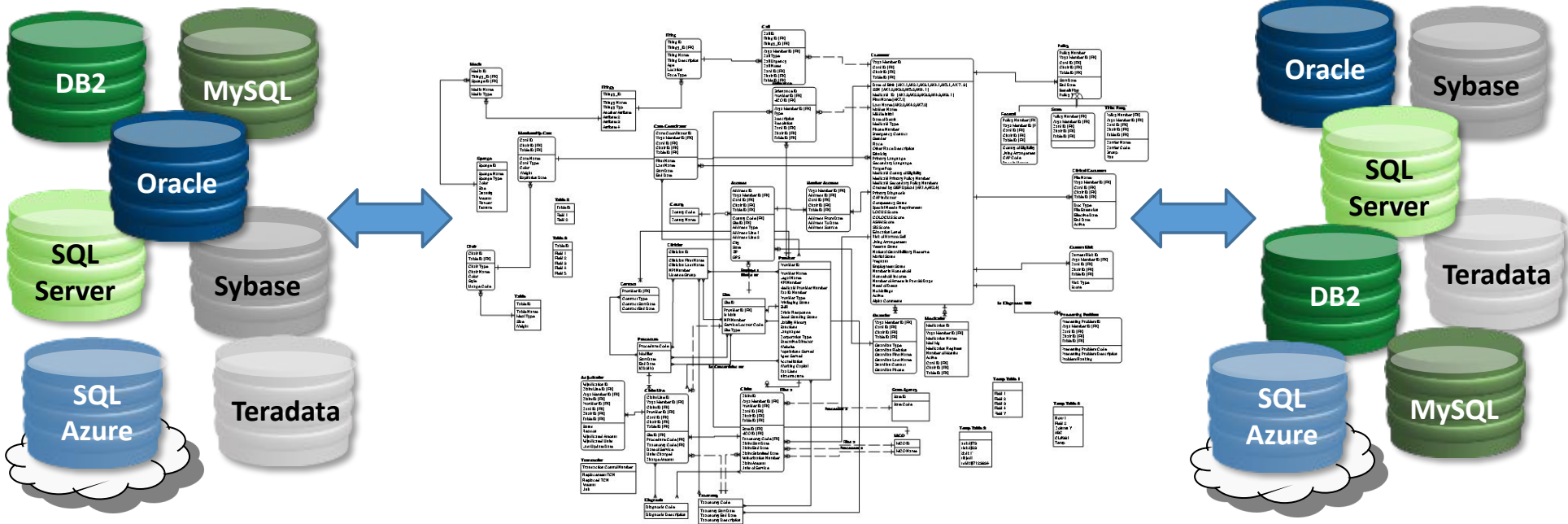

Forward Engineering

Reverse Engineering

An Agile Approach to Data Modeling

Rapid Development, Rapid Feedback

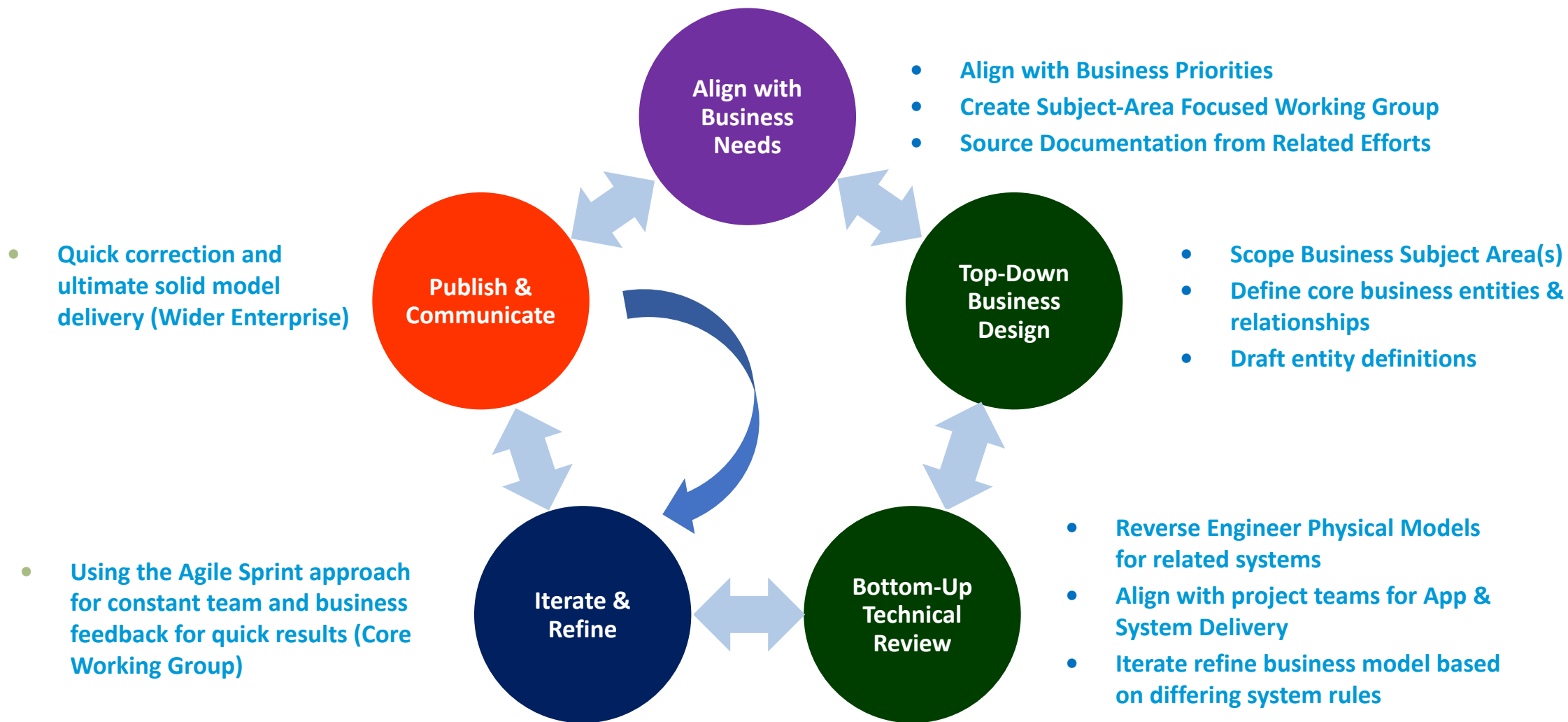

Focus on Communication & Iteration

Different Physical Models for Different Use Cases

Relational – Normal Form

- Reduce redundancy for operational data
- Increase data quality
- Ensure consistency (ACID transactions)

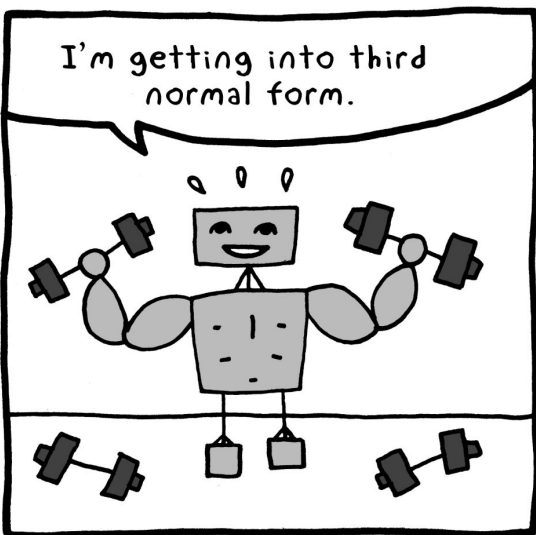

Dimensional– Star Schema

- Ease of reporting for summarized and historical data
- Ability to easily “slice and dice” for self-service reporting
- Performance and flexibility

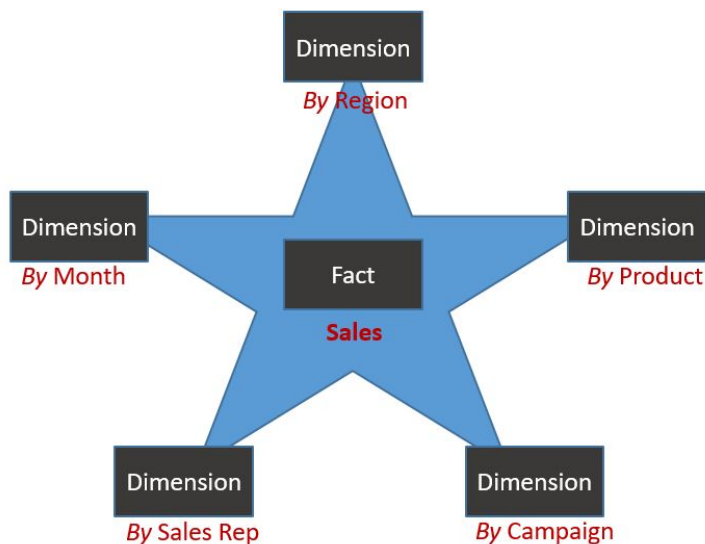

NoSQL

- Speed of retrieval, low latency
- High data volumes
- Flexibility for change

```

Key: Brewery_Pike_Brewing
{
  "Name": "Pike Brewing",
  ...
  "Brewery_Address": {
    ...
    City: Seattle
    Country: USA
  }
}
    
```

```

Key: Brewery_Pike_Brewing
{
  "Name": "Pike Brewing",
  "Brewery_Address_ID": "Brewery_Address_Pike_Brewing",
  ...
}

Key: Brewery_Address_Pike_Brewing
{
  "Brewery_Address": {
    ...
    City: Seattle
    Country: USA
  }
}
    
```

An arrow points from the top document to the bottom document, indicating a transformation or relationship.

...And More!

- There are numerous ways to model and store data.
 - Hierarchical/XML
 - Time series
 - COBOL Copybook!
 - S3 “buckets”
 - Data Vault
 - Etc...

No modeling technique is inherently “better” than another. Data use cases & purpose drives what “good” looks like.

Real-World Use Cases for Data Models

Examples from practice

These are all from real-world examples we've implemented. Data Models are everywhere.

Environmental Data Sampling

How do we align our scientific terminology?

Early Childhood Development

How do we create better outcomes for children?

eCommerce & Digital Transformation

What is data is key to our digital transformation?

University Student Support

Understanding the Student Journey with Data

Water Utility Data Modernization

How do we reflect our business rules into our new, digital environment?

Construction Contracting Efficiencies

How can a data model highlight inefficiencies in our business?

Agile Software Development

What data is involved in this user story?

Membership Org Customer Centricity

How do we define our customer/member?

Etc...

Real World Business Benefits

Some Specific Issues Solved with Data Modeling

Why did our website go down – losing two days of online sales?

Product Item Code: CHAR(10)

Why do we have so many duplicate suppliers?

A Supplier can have more than one address....

Who decided to sent renewal reminders to people who don't own our software?

A customer is an individual who has purchased one or more products.

How do we scope our data strategy & roadmap for the coming year?

This high-level data model shows the scope of our enterprise data.



Extra super-hero points

Summary

- **Speak the language of the business** in a conceptual and logical data model
- A good business data model **supports solid physical implementations.**
- **Data Modeling helps increase efficiency** and avoid unnecessary rework
- **All industries can benefit** from business-centric data modeling.
- **Data models solve real-world business problems (or stop them happening to begin with...)**



Who We Are: Business-Focused Data Strategy

Maximize the Organizational Value of Your Data Investment



In today's business environment, showing **rapid time to value** for any technical investment is critical.

But technology and data can be complex. At Global Data Strategy, **we help demystify technical complexity** to help you:

- Demonstrate the ROI and **business value of data**
- Build a data strategy **at your pace to match your unique culture** and organizational style.
- Create an **actionable roadmap for “quick wins”**, which building towards a long-term scalable architecture.

Global Data Strategy shares experience from some of the largest international organizations scaled to the pace of your unique team.

Global Data Strategy has worked with organizations globally in the following industries:

Finance · Retail · Social Services · Health Care · Education · Manufacturing
· Government · Public Utilities · Construction · Media & Entertainment ·
Insurance and more



Thoughts? Ideas?
Questions?